



CYCLONE

RX600

ADV TORQUE MASTER



ZS550SR engine

New generation of main power platform

Max. Power
43.5kW

Max. Torque
55Nm

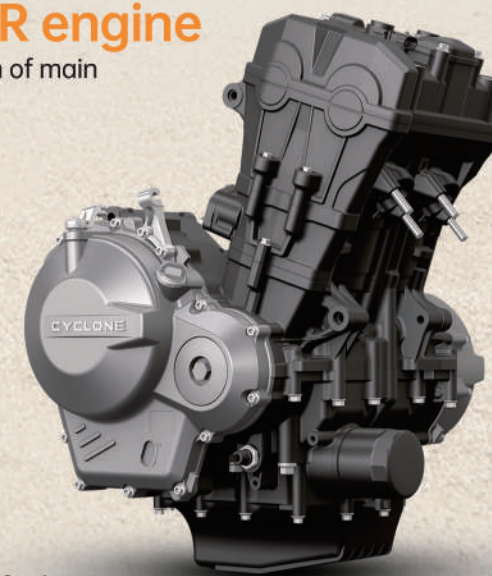

Power, torque, fuel consumption far ahead of the same level

- Smooth operation
- Strong low-end torque
- Clear gear shifting
- Minimal vibration
- Low fuel consumption
- Rich exhaust note



Distributed by



MFORCE BIKE HOLDINGS SDN. BHD. (751410-H)
1485, Jalan Seruling, Kawasan Perindustrian Valdor, 14200 Sungai Jawi, Pulau Pinang, Malaysia.
Tel: 604-545 2222 | Fax: 604-545 2288 | Email: help@mforce.my

Off-road performance

No challenges, only conquests



Specification

Model	SR600GY (RX600)
Engine Name	ZS550SR
Engine Type	2 cylinder in-line, 4-stroke, 8-valve, water-cooling, DOHC
Displacement (ml)	550.4
Bore x Stroke (mm)	72x67.6
Compression Ratio	11:01
Max. Power (kW/rpm)	43.5/8,500
Max. Torque (Nm/rpm)	55/6,500
Max. Speed (km/h)	165
Fuel System	EFI
Ignition	ECU
Starting System	Electric
Brake	Front/Rear: Disc, ABS
Tire	Tubeless Tire; Front: 110/80R19, Rear: 150/70R17
LxWxH (mm)	"2,180x870x1,399(WITHOUT 3 BOXES) 2,230x990x1399(WITH 3 BOXES)"
Wheelbase (mm)	1,425
Seat Height (mm)	820/790
Min. Ground Clearance (mm)	175
Curb Weight (kg)	"219 (WITHOUT 3 BOXES) & 230(WITH 3 BOXES)"
Fuel Tank Capacity (L)	18

*All figures and specifications are subject to change without prior notice.

Switchable dual channel ABS

Front and rear dual channel ABS
On: It ensures cruising safety
Off: It allows off-road adventures to the limit



Switchable TCS

On: Prevent slipping at startup or on wet roads
Off: Fully unleash torque and get rid of all obstacles

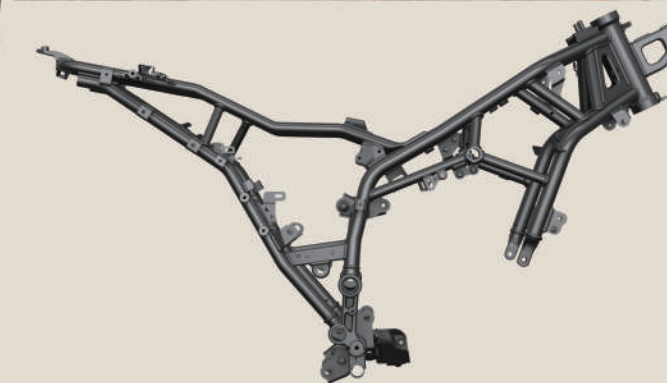

ADV-specific braided frame

Cradle structure design, calmly tackling extreme challenges

High strength
345MPa

Yield strength of the frame
International brands in the same level: 235MPa

High toughness
470-630MPa

Frame tensile strength
International brands in the same level: 370-500MPa

High rigidity
400-600kN/m

Frame bending stiffness
International brands in the same level: 300-450kN/m

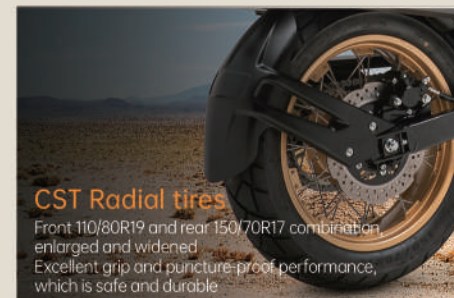

CST Radial tires

Front 110/80R19 and rear 150/70R17 combination enlarged and widened
Excellent grip and puncture-proof performance, which is safe and durable



Brake system+dual channel ABS

Front opposite four-piston caliper+rear dual-piston caliper, powerful braking, stop at your command



High-level mute muffler

With a larger muffling chamber volume, the exhaust note is richer, allowing you to ride freely through mountains and rivers



Professional ADV shock absorber system

Front 21-level adjustable upside down shock absorber
Rear 15-level adjustable rebound damping, multi-link central rear suspension
Vibration filtering performance is greatly improved